

**PRODUCT DESCRIPTION**

Grease separators are designed to keep and separate grease, fats and other light liquids from the waste water. They are suitable for industrial and catering establishments such as restaurants, kitchens, shopping malls, ...

Contaminated waste water must be purified of grease and fats before it drains into the waste water treatment plants or sewage systems.

RoFett grease separator consist of two chambers, a settling chamber and a grease separator. In both chambers the density of contaminated waters and built in equipment ensure efficient separation of light liquids from water. Flat bottom of the tank allow us to install the separator as free standing in basements or under washbins.

Up to 100 mg/l of fats is allowed to outflow to the sewage systems or up to 20 mg/l to the watercourse.

It is dimensioned and designed in accordance with SIST EN 1825-1 and SIST EN 1825-2: 2002.

**TECHNICAL DATA RoFett NG 10**
**ROTO GREASE SEPARATOR ADVANTAGES**

- High cleaning efficiency**
- Low maintenance costs
- Long life service**
- Easy and fast installation
- Fast delivery**
- ROTO installation possibility
- Made according to EU standards**
- Calming inlet pipe
- Telescopic adjustable extension**
- Slovenian product

Technical data	Values
Nominal flow	10 L / s
Total volume	5000 L
Settler volume	2095 L
Grease separator volume	2120 L
Maximum grease amount	1220 L
Installation	Underground installation
Dimension L x D x H [mm]	2450 x 1800 x 2000 - 2500 mm
Diameter of revision openings	1 x $\Phi$ 600
Material	Polyethylene [PE]
Inflow and outflow pipe diameter	DN 160
Standard	SIST EN 1825-1, SIST EN 1825-2
Grease content at the outlet	/
UV resistant material	Yes
Cover	PE walk - on cover up to 200 kg
Water outflow	In sewage system or WWTP

## MECHANICAL RESISTANCE AND STABILITY

Mechanical resistance and stability is checked ( Report no.: P 0865 / 12 – 680 – 2 ) by the institute:  
Slovenian national building and civil engineering institute, Dimičeva ulica 12, 1000 Ljubljana



## WATERTIGHTNESS

Watertightness is checked ( Report no.: P 0865 / 12 – 680 – 1 ) by the institute:  
Slovenian national building and civil engineering institute, Dimičeva ulica 12, 1000 Ljubljana

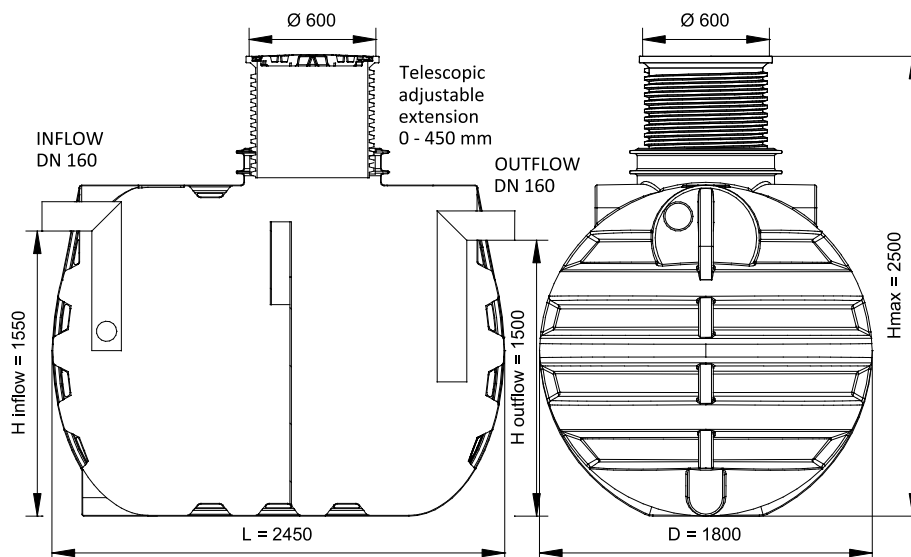

## ADDITIONAL INFORMATIONS

### INSTALLATION

Installation of the RoFett grease separator is simple and does not require heavy mechanisation. To install the separator it is necessary to excavate the pit, install the separator and fill it with the water at the same time. Connect it with the inflow and the outflow pipes (DN 160 connections). Follow the instructions on the QR code.



Instructions for installation

### OPERATION

Water contaminated with waste oils, grease and fats flows into the first chamber of the separator. First chamber has a function of a settler, where the solids is settling to the bottom and the grease is raised to the surface. Remaining water mixed with the grease drains into the second chamber which has a function of a secondary separator, where the remaining grease is raised.

### MAINTENANCE

The control of the grease separator must be carried out in accordance with the technical map and the operation logs. Maintenance of the grease separator involves the removal of the sediments, grease and cleaning of the tank. Cleaning of the tank should be performed by the maintainer or authorized person to ensure that the waste is handled in accordance with the legal regulations.



Roto Eco d.o.o.

Puconci 12, 9201 Puconci,

SLOVENIA

Customer support: (+386) 2 5252 152

Technical support: (+386) 2 5252 196

Web page: [www.rotoECO.eu](http://www.rotoECO.eu)

All rights reserved, including the rights of photomechanical reproductions and storage on electronic media. The manufacturer reserves the rights to change the product. Any commercial use of the processes and working procedures assumed in this document is prohibited. Although information, texts and photos were carefully collected. The mistakes can not be completely excluded. The publisher and editors can not assume legal responsibility or guarantee any incorrect information. The publisher and editors are grateful for any possible suggestions for improvements and warnings of possible mistakes in the text.